



# **TECHNICAL SPECIFICATION FOR FIELD DRAINAGE SCHEMES**

**\*\*\*\*\***

## **Acknowledgements.**

The Land Drainage Contractors Association acknowledges the assistance of the many government and non-government bodies, member companies and individuals in producing this Technical Specification.

In particular the LDCA acknowledges the work of the officers of the Land & Water Services of MAFF Agriculture Development and Advisory Service (ADAS) and is grateful for permission to print illustrations and other technical material previously published by ADAS.

The work and effort of the LDCA Technical Committee (R.E. Hughes, R. Longdin, and J.K. Hoare) is also warmly acknowledged.

January 1998.

Whilst all reasonable care has been taken to ensure the technical correctness of this Specification, the LDCA can accept no liability for errors, omissions, or the consequences of any such errors or omissions.

This Specification is not intended to form the basis of any specification or contract unless agreed separately in writing between the customer and the contractor. The Association reserves the right to change or modify any part of this Specification at any time without prior notice.

# LDCA TECHNICAL SPECIFICATION FOR FIELD DRAINAGE SCHEMES

## CONTENTS

- 1.0 GENERAL
  - 1.1 Introduction.
  - 1.2 Statutory Authorities
  - 1.3 British Standards
  - 1.4 Materials not covered by British Standards
- 2.0 DESIGN
  - 2.1 Site Examination
  - 2.2 Surveying Instruments
  - 2.3 Pipe Size Design
  - 2.4 Culvert Strength and Bedding Design
  - 2.5 Drainage Plans
  - 2.6 Grant Aid Requirements
  - 2.7 Computer Programmes
- 3.0 UNDER DRAINAGE
  - 3.1 MATERIALS
    - 3.1.1 General
    - 3.1.2 British Standard and Quality Requirements
      - 3.1.2.1 Corrugated and Smooth Plastic Pipes
      - 3.1.2.2 Pre-wrapped Plastic Pipes
      - 3.1.2.3 Clayware Field Drainage Pipes
      - 3.1.2.4 Concrete Pipes
      - 3.1.2.5 Pitch Fibre Pipes
      - 3.1.2.6 Pipe Junctions and Connectors
      - 3.1.2.7 Outfall Pipes
      - 3.1.2.8 Headwalls
      - 3.1.2.9 Inspection/Junction Chambers
      - 3.1.2.10 Silt Traps/Inlet Chambers
      - 3.1.2.11 Vermin Grids
      - 3.1.2.12 Permeable Backfill Materials
      - 3.1.2.13 Concrete and General Building Materials
  - 3.2 WORKMANSHIP
    - 3.2.1 General
    - 3.2.2 Underground Services
    - 3.2.3 Soil Conditions
    - 3.2.4 Trench Digging and Excavation
    - 3.2.5 Grade Control
    - 3.2.6 Drain Laying
    - 3.2.7 Making Drain Connections
    - 3.2.8 Connecting to Existing Drains
    - 3.2.9 Air Temperature Limitations
    - 3.2.10 Sealed Joints
    - 3.2.11 Backfilling Excavated Material
    - 3.2.12 Backfilling with Permeable Fill
    - 3.2.13 Disposal of Surplus Soil
    - 3.2.14 Trenchless Heave
    - 3.2.15 Soft Ground
    - 3.2.16 Inspection Chambers
    - 3.2.17 Underdrain Outfalls
    - 3.2.18 Drains Taking Surface Run-off
    - 3.2.19 Replacement of Ditches with Pipes
    - 3.2.20 Drain Bridges
- 4.0 DITCHING
  - 4.1 General
  - 4.2 Clearance Work before Excavation
  - 4.3 Ditch Dimensions
  - 4.4 Existing Pipe Drain Outfalls
  - 4.5 Silt in Excavated Length
  - 4.6 Slips
  - 4.7 Spoil from Ditch Excavation
  - 4.8 Fencing to Ditches
  - 4.9 Cattle Drinking Bays
  - 4.10 Erosion Control
- 5.0 BRIDGES AND CULVERTS
  - 5.1 DESIGN
    - 5.1.1 Diameter
    - 5.1.2 Construction
      - 5.1.2.1 Usable Culvert Width
      - 5.1.2.2 Large Diameter Corrugated Plastic Pipes
      - 5.1.2.3 Vitrified Clay or Concrete Pipes
      - 5.1.2.4 Culvert Bedding and Alignment
      - 5.1.2.5 Erosion Control
      - 5.1.2.6 Headwalls for Culverts
      - 5.1.2.7 Culverts with Sloping Earth Ends
      - 5.1.2.8 Culverts used by Heavy Vehicles
    - 5.1.3. Design of Clear Span Bridges
  - 5.2 WORKMANSHIP
    - 5.2.1 Gradient and Pipe Bedding
- 6.0 MOLE DRAINAGE AND SUBSOILING
  - 6.1 MOLE DRAINAGE
    - 6.1.1 General
    - 6.1.2 Timing of Operation
    - 6.1.3 Mole Channel Depth
    - 6.1.4 Spacing of Mole Channels
    - 6.1.5 Size and Shape of Mole Channels
    - 6.1.6 Directions of Moling Operation
    - 6.1.7 Mole Drainage Equipment
    - 6.1.8 Mole Channels Drawn Through Loose Soil
  - 6.2 SUBSOILING
    - 6.2.1 General
    - 6.2.2 Timing of Operation
    - 6.2.3 Subsoiling Depth
    - 6.2.4 Tine Spacing
    - 6.2.5 Direction of Subsoiling
    - 6.2.6 Subsoiling Equipment

7.0 MISCELLANEOUS ITEMS RELATING  
TO DITCHING AND  
UNDERDRAINAGE

- 7.1 Hill Gripping
- 7.2 Pump House Structures and Wells
- 7.3 Drain Jetting
- 7.4 Spring Drainage

8.0 CONSERVATION

- 8.1 General Considerations
- 8.2 Water Courses
- 8.3 SSSI's
- 8.4 Ancient Monuments

9.0 SAFETY

- 9.1 General
- 9.2 Health and Safety at Work Act 1974
- 9.3 Important Safety Aspects of Field  
Drainage Works
- 9.4 Underground Services
  - 9.4.1 Notification
  - 9.4.2 Working in the Vicinity
- 9.5 Overhead Electricity Cables
- 9.6 Lasers

# LDCA TECHNICAL SPECIFICATION FOR FIELD DRAINAGE SCHEMES

## 1.0 GENERAL

### 1.1 Introduction

This specification sets out Minimum Standards for Design, Workmanship and Materials in field drainage schemes as considered necessary by the Land Drainage Contractors Association (LDCA).

Members of LDCA undertake to use and supply materials to the specified standards and to maintain the standards of workmanship set down in this specification. In exceptional cases, deviation from this standard may be necessary to meet particular physical conditions or special requirements.

### 1.2 Statutory Authorities

The requirements of Statutory Authorities having any interest in any part of the work shall be observed. The Contractor shall comply with such Acts, Bye-laws or Regulations which apply at the time of installation.

### 1.3 British Standards

Where a British Standard is specified it is to be the current edition at the time of carrying out the work.

British Standard Publications can be purchased from BSI, Linford Wood, Milton Keynes MK14 6LE.

### 1.4 Materials not covered by British Standards

Where no British Standards exists for proprietary items, materials must be shown to Be suitable for the specific purpose.

## 2.0 DESIGN

### 2.1 Site Examination

Topographical (level) and soil surveys carried out before design must be adequate to allow an accurate assessment of drainage problems and a full and adequate drainage design to be compiled.

The location and condition of any existing drains and buried devices should be determined where possible and, incorporated into the new system.

Consultation with the land owner and all relevant authorities must take place before the work commences. Scheme design should, where possible, avoid crossing buried pipes or cables and eliminate the need to work beneath overhead electricity cables.

### 2.2 Surveying Instruments

Optical or Laser surveying equipment must be regularly maintained, calibrated and used in accordance with the instructions.

### 2.3 Pipe Size Design

Pipe sizes should at least conform to MAFF Reference Book 345 - "The Design of Field Drainage Pipe Systems", or another approved system of design.

Lateral Drains, Restricted Inlet Drains, Interceptor Drains, Open-inlet Piped Ditches and Culverts must be adequate for the design flows.

Where culvert minimum sizes are laid down by the Water Authorities or Internal Drainage Boards, the Contractor must conform to the requirements.

### 2.4 Culvert Strength and Pipe Bedding

When designing culverts attention must be paid to the design loads expected. Pipe strength and bedding must be adequate to withstand these loads. Appendix A details pipe design loads and bedding factors required for culverts under farm tracks and farm roads. Professional advice should be sought from the relevant authority when designing culverts which pass beneath roads carrying heavy vehicles.

- 2.5 **Drainage Plans**  
Drainage layouts and designs must be based on adequate level surveys. All Proposal and Final Plans for underdrainage and ditching must be prepared using the standard symbols and colours to a minimum scale of 1/2500, as shown in Appendix B. A negative of a clear aerial photograph superimposed and printed on an OS map of the field is accepted as showing the layout of the scheme from which measurements can be scaled. In addition, when submitting this in support of a claim for grant, the photograph must be supported by a certified statement, giving all the information which would be shown with a certified plan, i.e. details of total drain length, pipe size and type, use and depth of permeable backfill materials, details of mole drainage, subsoiling etc.
- 2.6 **Grant Aid Requirements**  
The design must be eligible for grant aid where applicable, unless the client specifies otherwise.
- 2.7 **Computer Programmes**  
Computer programmes used for pipe size selection must be soundly based on acceptable data.

### 3.0 UNDERDRAINAGE

#### 3.1 MATERIALS

##### 3.1.1 General

All materials delivered to the site must be inspected before use. Where a British Standard applies, a check must be made to ensure that materials have been stored and supplied in accordance with the regulations and that the Kite Mark is carried where applicable. A supply of material carrying a Kite Mark does not in itself guarantee that the materials conform to the British Standard on delivery. A visual check must be made and the production date noted.

##### 3.1.2 British Standards and Quality Requirements

###### 3.1.2.1 Corrugated and Smooth Bore Plastic Pipes

Plastic Pipes (up to 200mm diameter) and Connectors must conform to BS4962 (1989) or an equivalent European Standard. Larger pipes, in excess of 200mm diameter, not covered by BS4962 must be shown to be suitable for the specific purpose and possess an Agrément Certificate.

###### 3.1.2.2 Filter wrapped Plastic Pipes

Filter wrapped pipes must be suitable for their purpose. Wrapping materials must be undamaged and firmly fastened to the pipes.

###### 3.1.2.3 Clayware Field Drainage Pipes

Clay tiles shall conform to BS 1196 where applicable.  
Clay pipes shall conform to BS 65.

###### 3.1.2.4 Concrete Pipes

Concrete pipes fall into four types,

- a) Dense pipes with flexible joints to BS 5911 Part 1 shall normally be used for foul water.
- b) Dense pipes with ogee joints to BS5911 Part 3 shall be used for surface water.
- c) As b) but perforated (100mm sq. per metre length) shall be used to permit ingress of water.
- d) Porous concrete pipes to BS 1194 shall be used to permit infiltration in sandy conditions.

**Note 1:** Types a) b) and c) have high cement contents and may be safely used when conditions are up to Class 2 sulphate and down to pH 5 acid. Type d) have

large areas exposed to water passage and should not be used in aggressive conditions (e.g. when pH is below 5.5 or high concentration of sulphates can be expected.) For Class 3 sulphate conditions, sulphate resisting cement should be specified for all types.

**Note 2:** Concrete pipes are normally reserved for Civil Engineering applications. When used it is important to specify the correct strength of pipe, see appendix A for guidance.

#### 3.1.2.5 **Pipe Junctions and Connectors**

Purpose-made junctions and connectors must be used when joining pipes. A range of suitable junction and connector types is shown in Appendix C.

Connectors for in-line joining of plastic pipes must be positive and comply with the requirements of BS 4962.

#### 3.1.2.6 **Outfall Pipes**

Outfall pipes must be rigid and frost resistant and a minimum length of 1.5m.

#### 3.1.2.7 **Headwalls**

Headwalls must be of a suitable type and materials must be strong and frost resistant.

Typical headwall constructions are shown in Appendix D.

#### 3.1.2.8 **Inspection/Junction Chambers**

Chambers to facilitate junctions and inspection must be suitable for their function and strong enough to withstand surface loads. Appendix E shows typical designs.

#### 3.1.2.9 **Silt Traps/Inlet Chambers**

Appendix F details typical construction for silt traps and inlet chambers.

#### 3.1.2.10 **Vermin Grids**

All drain outfall pipes should be fitted with a suitable grating to prevent vermin from entering the drainage system. All gratings fitted to the outfalls of open ended drains must be hinged outwards.

#### 3.1.2.11 **Permeable Backfill Materials**

Permeable backfill, when specified must come from a reputable source. It must be clean, free from dust or soil and be between 5mm and 50mm in size.

Gravel, stone chips, slag, foam slag, hard clinker Lytag or other suitable and durable material may be used. All materials must be strong, durable and free from chemical pollutants.

#### 3.1.2.12 **Concrete and General Building Materials**

Materials used for construction of headwalls etc. shall conform to the relevant British Standard as follows:

Concrete	BS 5328 (1981) amended June 1985
Additives	BS 5075 (1982)
Concrete Blocks	BS 6073 (1981) amended 1982 and 1984
Bricks	BS 3921 (1974)

### 3.2 **WORKMANSHIP**

#### 3.2.1 **General**

Installation machinery shall be in good condition properly adjusted and suitable for the site conditions and comply with current Health and Safety requirements.

All materials on site shall be stored and handled so as to prevent damage during installation in accordance with the manufacturers' instructions.

#### 3.2.2 **Underground Services**

At the design stage full enquiries should be made to all statutory undertakers to establish the existence of their underground plant. Every precaution must be taken to locate and mark underground services before work commences. Location using approved plans

and/or location equipment must be followed by hand digging to determine the exact position of the pipes and cables. Location of gas pipes and oil pipelines owned or managed by BPA must take place in the presence of their staff. In the event of any damage to buried services the relevant authority must be informed. At all times, work must comply with the Health and Safety at Work Act 1974 and be in accordance with any special limitations imposed by the utility concerned.

### **3.2.3 Soil Conditions**

Surface and sub-surface soil conditions shall be such as to avoid unnecessary smear or compaction at the surface or near the drain. High water tables, wet topsoil, puddles etc. can be detrimental to the drainage installation. Work should only proceed in such conditions at the express wish of the client. Surface tracking should be minimised at all times, especially when draining through growing crops.

### **3.2.4 Trench Digging and Excavation using Continuous Chain Trenchers**

Drain trenches should run in straight lines (unless topographical features dictate otherwise), at the required depth and gradient.

The trench bottom must be smooth and V-Shaped so as to bed the pipes securely. The width of the trench at the bottom is to conform as nearly as possible to the outside diameter of the pipe.

The minimum depth of cover over any land drain is to be 600mm. If this is not physically possible appropriate protection must be provided.

The same requirements governing depth, width and shape, shall apply to both trenchless and trenched installation of drainage pipes.

Where mole channels are to be drawn across the lateral drains, the pipe depth must be such that the invert of the mole channel is at least 100mm above the top of the pipe. A minimum trench width of 100mm is recommended when permeable backfill is placed for use with mole drains.

### **3.2.5 Grade Control**

Pipes must be laid to an even, specified grade without backslaps.

Where laser grade systems are employed, the siting of the laser transmitter must be correct and the direction of operation set to give true grades.

### **3.2.6 Drain Laying**

All pipes must be laid on a firm smooth bed, shaped to support the pipe. No loose materials shall be allowed to fall beneath the pipes.

Corrugated plastic pipes must be laid in a straight line free from kinks or stretching. Well-fitting tensile stress-resistant connectors must be used to join pipes.

Clay or concrete pipes should be laid close together to prevent ingress of material. Where flexible pipes are laid in a wide trench excavated by a back-actor particular care should be taken to bed and surround pipe with suitable permeable backfill.

All drain lines should be plugged at the upper end to avoid ingress of soil or animals.

### **3.2.7 Making Drain Connections**

Purpose made rigid junctions (see Appendix C) must be used when connecting lateral drains to main drains. Under no circumstances must the lateral drain be permitted to extend into the main drain.

### **3.2.8 Connecting to Existing Drains**

Existing drains which are still active must be positively connected into the new system. Unless superseded by the new drains, other drains which might carry water are to be connected to the new drains either by a positive connection or with permeable backfill. A maximum gradient of 1:20 is recommended when connecting new drains to existing drains. A well-fitting adapter piece must be used.

### 3.2.9 **Air Temperature Limitations**

Care must be taken at all times in handling uPVC pipes at low temperatures. Pipe laying and the placement of permeable backfill over uPVC pipes should not normally be carried out when air temperature is below 0°C.

Where other factors demand that pipes be laid in sub-zero temperatures great care must be taken and the advice of the manufacturer sought.

Polypropylene and Polyethylene corrugated pipes can be laid in sub-zero temperatures to a recommended minimum temperature of -10°C.

In extremely high temperatures care must be taken to avoid stretching or collapse of plastic drain tubes.

### 3.2.10 **Sealed Joints**

Pipes with sealed joints or unperforated corrugated plastic pipe (of similar standard to perforated pipe) must be used where pipes are laid:

- (a) Through windbreaks consisting of trees and /or shrubs
- (b) Closer than 5m from hedges of trees (other than in orchards.)
- (c) Where leakage from the drain could cause erosion or scouring and displacement of the pipe.

### 3.2.11 **Backfilling Excavated Material**

Pipe trenches are to be carefully backfilled as soon as practicable after installation with excavated material placed in such a way that the pipes are not damaged or displaced.

Trenches should be filled to a level sufficiently above the surface to allow for settlement within reasonable limits.

Backfill must not be placed over the pipes if it is in a slurry condition.

### 3.2.12 **Backfilling with Permeable Fill**

Suitable permeable backfill is to be carefully placed over the pipes to the specified depth. Any loose soil on the pipe must be removed and care must be taken to avoid mixing soil with the backfill material. Where fitted, gravel hoppers should be used to regulate the depth of the permeable backfill and to prevent the ingress of soil.

The permeable backfill must be laid in a manner which does not displace or damage the pipes.

Where mole channels are to cross the lateral drains permeable fill should be a minimum of 100mm wide and must not be less than 150mm above the invert of the mole channel. See Appendix J.

### 3.2.13 **Disposal of Surplus Soil**

Surplus material which is not of an injurious nature is to be spread evenly in the vicinity of the drain line. Materials such as large stones, roots etc. likely to damage implements or stock, or of a size and character abnormal to material found on the surface of the field, is to be disposed of as agreed with the client.

### 3.2.14 **Trenchless Heave**

In grassland, the heave caused by trenchless drainage should be reduced by:

- (i) Rolling down immediately with the drainage machine or heavy roller.
- (ii) Discing or rotovating along the drain line and re-seeding in agreement with client

Where mole drains are to be drawn across trenchless installed laterals soon after installation the original ground levels should be restored and the soil thoroughly consolidated.

### 3.2.15 **Soft Ground**

In peat, running sand, lines of old ditches and other conditions where it is impossible to obtain a firm bedding on which to lay the drain, special provision is to be made to maintain alignment.

The number of ditch or trench crossings should be reduced to a minimum by the installation of a collector drain along the higher side .

Where the ditch or trench to be crossed is only slightly deeper than the drain, an economic crossing can be made by filling the ditch or trench with well consolidated

spoil and laying a continuous length of pipe on a suitable support which must be well bedded into undisturbed ground on both banks.

Where the depth of the ditch or trench to be crossed is significantly below the depth of the drain, one of the following methods should be used:-

- (i) The redundant ditch or trench should be excavated to firm ground and filled to drain level with lean mix concrete.
  - ii) The crossing may be bridged by means of a suitable diameter heavy-quality galvanised steel or cast iron tube laid to the existing gradient and of length equal to crossing width plus at least 1200mm. Second-hand material may be used. In the case of a very wide trench the tube may have to be supported as described for method (iii).
  - (iii) The crossing may be spanned by a purpose made beam, plastics or other pipe of similar character supported by means of a bridge, the length of the support being equal to the trench crossing plus at least 1200mm. The pipe should be surrounded with a granular material of size 20mm or less before completion of the backfill. (See note 3.2.20)
- In such soil conditions machines having attitude control should be employed to ensure correct pipe grade is maintained.

#### 3.2.16 **Inspection Chambers**

Inspection chambers should be constructed in accordance with the advice given in Appendix E. Care must be taken to effectively seal the inlet and outlet pipes in the chamber walls.

#### 3.2.17 **Underdrain Outfalls**

A properly constructed outfall, of a suitable type, is to be provided wherever a drain pipe discharges into an open channel. The invert, wherever possible, should be positioned at least 150mm above the normal ditch level.

The final 1.5m of buried drain pipe must be of a rigid type. Any projection of the drain pipe beyond the bank must also be rigid and frost resistant. Fitting of vermin grids is recommended. Drain markers are recommended at outfalls as agreed with the client. Headwall designs must include slope protection and splash plates and must be securely anchored in position. Typical designs are shown in Appendix D.

#### 3.2.18 **Drains Taking Surface Runoff**

Whenever water flows into an open pipe, either from the surface or an open channel, the pipe must be provided with a silt trap and grating. Typical suitable designs are shown at

Appendix F. Designs based upon precast concrete chambers manufactured to BS5911 are acceptable in appropriate cases, as are other proprietary units. Care must be taken to seal the pipe in the inlet chamber wall.

#### 3.2.19 **Replacement of Ditches with Pipes**

Any trees, stumps, hedges and roots on the line of the pipe shall be removed and disposed of before the pipes are laid. Care should be taken to locate any existing functioning drains and to connect these to the new pipe as described in paragraph 3.2.8. In circumstances where the existing system is extensive, or the new pipeline is likely to be subjected to high velocities or surcharges, special provision for connection to (or by-passing) the new pipe must be made.

Pipes are to be laid on a firm bed and surrounded with suitable permeable fill.

Twin wall plastic pipes of a suitable diameter may be used to pipe ditches. Where larger diameter plastic pipes are used particular care must be taken to ensure that pipe-bedding and side fill is suitable and properly compacted for the depth and loads applied in accordance with the manufacturers' advice.

**NOTE:** Appendix A indicates bedding types and design load factors for plastic and concrete pipes.

### 3.2.20 Drain Bridging Beams

Where pipe drains are to be laid in very soft conditions, across backfilled trenches, or similar situations, a rigid drain bridging beam must be used to support the pipe, these must rest on at least 600mm of firm soil on each side.

Soil beneath the drain beam must be firmly compacted and any voids totally filled.

Pipes may require fixing to the beam by a suitable method.

## 4.0 DITCHING

### 4.1 General

The following specifications refer to newly created ditches and to maintenance of existing ditches. Ownership of ditches and access rights should be determined before commencing work.

Consultation must take place with the client, and interested third parties to ensure that proper conservation practices are taken into account. Where a statutory authority, such as Water Authority or an IDB control the ditch or watercourse, consultation must take place and any special regulations or requirements complied with.

### 4.2 Clearance Work before Excavation

Before commencing clearance work consult the client concerning any conservation requirements. In many cases it may be sufficient to work from and clean up one side of the ditch only. Timing of clearance operations or ditch maintenance may have critical implications for wildlife, (avoid disturbing nesting or breeding animals), if in doubt seek expert advice.

Clearance work on hedges and banks shall be done as necessary, in advance of excavation. Over-growth on the banks and in the ditch shall be cut down or grubbed out and the hedges trimmed sufficiently to allow correct ditch excavation. Tree branches are to be lopped with reasonable care to avoid damage to tree or the local amenities. All trimmings and over-growth are to be burnt, mulched or carted away and not mixed with, or covered by, the material dug out of the ditch. Proper attention to conservation and amenity must be given at all times.

### 4.3 Ditch Dimensions

Ditches are to be of sufficient capacity for the catchment area drained. Dimensions and gradients must be suitable to avoid erosion and to form a stable channel. Side slopes should be neatly trimmed and finished and care should be taken to avoid endangering the stability of any adjacent structure or hedge.

The following slopes for open channels in the main soil types can be used as a guide.

#### *Channel side slopes. Horizontal : Vertical*

<i>Soil</i>	<i>Channel less than 1.3m deep</i>	<i>Channel greater than 1.3m deep</i>
Fen Peat	Vertical	½ : 1
Heavy Clay	½ : 1	1 : 1
Clay or silt loam	1 : 1	1½ : 1
Sandy Loam	1½ : 1	2 : 1
Sand	2 : 1	3 : 1

### 4.4 Existing Pipe Drain Outfalls

The sides of the ditch are to be examined for old drain outlets. If functional, these are to be made good to the standard described in Section 3.2.17 in agreement with the client.

### 4.5 Silt in Excavated Length

Accumulations of silt forming in the excavated length during the course of the work shall be removed before the scheme is completed.

#### 4.6 **Slips**

Slips in the side slopes that occur while work is in progress, or, shortly after completion, are to be made good, and appropriate remedial measures taken with the agreement of the client, to prevent their recurrence.

#### 4.7 **Spoil from Ditch Excavation**

Material dug from the ditch shall be deposited not less than 1m from the edge of the ditch and spread evenly, suitable for normal cultivations, on the field surface adjoining the ditch. Large stones, roots and other materials of a size or character abnormal to materials normally found in the field, which could damage implements or stock, are to be removed as agreed with the client.

Where the material cannot be spread as excavation proceeds, it is to be temporarily heaped along the field side of the ditch not less than one metre from the edge of the ditch so that it can be spread mechanically. Grips must be left to prevent surface water from being held by spoil. In exceptional cases, where spreading is not desirable or practicable (e.g. roadside ditches with narrow verges), the material is to be carted away. All such activities are to be carried out in consultation with the client and any particular requirements complied with as agreed.

#### 4.8 **Fencing to Ditches**

Guard fencing for ditches is intended as a deterrent to farm animals; it is not expected to be completely stock proof. The minimum standard for erection is as follows:

The fence is to consist of one or two lines of plain or barbed wire, erected on wooden posts.

If one wire is to be used it is to be fixed 700mm to 800mm above the ground; if two wires are used the top one is to be fixed 700mm to 800 and the lower one 300mm to 450mm above the ground.

The fence shall be parallel with the ditch and at least 500mm from the edge of the ditch and shall be erected as the ditching work proceeds, to prevent damage to new work by stock.

Straining posts are to be sunk not less than 800mm in the ground, firmly strutted in the direction of the strain, and placed at each change of direction or acute variation of level and at intervals of not more than 150m on the straight. Intermediate posts are to be driven not less than 500mm into the ground and spaced at intervals of not more than 5.5 metres. Line wires are to be strained tightly between straining posts. Plain wire is to be attached by strainers at both ends; barbed wire may be stapled to straining posts or attached by strainers at one or both ends. Line wires are to be attached to intermediate posts by staples which are to be driven only as far as will allow the wire the minimum of freedom in the staple.

Unless some other form of protection exists, the wire or wires are to be returned across the ditch at all gateways, culverts, other crossings and ends of ditches.

Alternatively wooden rails may be provided.

Drinking bays are to be fenced to prevent stock treading in the stream and to protect the sides of the ditch and drinking place.

#### 4.9 **Cattle Drinking Bays**

Cattle drinking bays must be constructed to a suitable standard and properly fenced. A typical construction is shown in Appendix G.

#### 4.10 **Erosion Control**

Ditch bed slopes and side slopes must be sufficient to allow for self-cleansing flow and adequate bank stability without causing erosion.

Normally ditch bottoms should be smooth and uniform in grade to avoid excessive scouring, erosion and consequent collapse. Stepping of ditch bottoms must be avoided except where deeper pools of suitable proportions are included for conservation reasons.

## 5.0 BRIDGES AND CULVERTS

### 5.1 Design

#### 5.1.1 Diameter

Culverts shall be capable of accommodating the anticipated design flow and shall be a minimum of 225mm in diameter.

Catchment area must be carefully determined and pipe sizes selected using an accepted system of design such as MAFF Reference Book 345 - "The Design of Field Drainage Pipe Systems."

Mandatory minimum culvert diameters may be specified by interested Statutory Bodies, such as Water Authorities. Consultation with the appropriate Authority when dealing with large catchment areas or urban development, is essential.

#### 5.1.2 Construction

Typical designs for culvert construction are shown in Appendix H.

##### 5.1.2.1 Usable Culvert Width

A usable culvert width of 6m is recommended where vehicles cross a culvert.

Where necessary a pavement of hardcore 225mm thick, extending for the usable width of the crossing and to undisturbed ground on both sides should be provided.

##### 5.1.2.2 Large Diameter Twin Wall Plastic Pipes

Where corrugated plastic pipes are installed as culverts in accordance with manufacturers' specific instruction, particular care and attention to detail in bedding and backfilling is essential.

##### 5.1.2.3 Vitrified Clay or Concrete Pipes

Where vitrified clay or concrete pipes are used for culverts positive joints must be used.

##### 5.1.2.4 Culvert Bedding and Alignment

Pipes are to be set on a firm bed and in proper alignment. The trench bottom is to be recessed where necessary to accommodate the collar of spigot and socket joints.

The pipes are to be set so that the invert at the upstream end is below the bottom of the ditch.

Where the total depth of cover is less than the diameter plus 300mm (to a total fill depth of 600mm) concrete or clay pipes are to be wholly surrounded by concrete at least 150mm thick. In soft ground or where stability is endangered, special precautions, such as concrete bedding and haunching or the use of a continuous pipe will be necessary. Where the manufacturer of the pipes specifies precautions to be taken in laying the pipes these are to be observed.

##### 5.1.2.5 Erosion Control

Where erosion is likely at the downstream end of the culvert, protective measures (e.g. bagwork, stone pitching, concrete slabs) are to be provided on the bed, and if appropriate, on the sides of the ditch.

##### 5.1.2.6 Headwalls for Culverts

Adequate provision is to be made to retain the backfill against the pressure of traffic using the crossing. In good ground, the headwall is to be built into each bank for a distance not less than 450mm throughout its height. Typical designs for culverts up to 1.5m deep in good ground are shown in Appendix H. Headwalls for culverts in excess of 300mm diameter should incorporate a lintel over the pipe.

##### 5.1.2.7 Culverts with Sloping Ends

Where headwalls carrying the full depth of fill would be uneconomic, and sloping ends, with or without low headwalls are used, these slopes are not to be steeper than 1½ horizontal to 1 vertical, or 1 to 1 if turfed. The length of the culvert should be extended by 1.0m or more depending on the depth of the culvert at each end to allow

a margin of 1000mm between each side of the roadway and the tops of slopes. A typical design is shown in Appendix H.

#### **5.1.2.8 Culverts used by Heavy Vehicles**

Culverts on farm roads and in other situations where they are likely to be used by heavy road vehicles, or farm machinery of a comparable weight, should be constructed to the standards in Appendix H, which assume a minimum cover of 600mm and a maximum of 3.0m.

#### **5.1.3 Design of Clear Span Bridges**

When it is necessary to construct a clear span bridge, the design must be based on such maximum loadings as the bridge is likely to carry. A substantial safety factor should be used to ensure that the design is adequate.

The LDCA recommends its members to use a qualified design engineer, such as a member of the Box Culvert Association, when constructing clear span bridges. In all cases Water Authority Approval must be obtained.

### **5.2 WORKMANSHIP**

#### **5.2.1 Gradient and Bedding of Pipes**

The pipe gradient through the culvert must be smooth and should closely approximate that of the adjoining ditch. The ditch bed downstream of the culvert should be graded to account for the deepening of the ditch at the culvert.

The pipes must be laid on a firm bedding in accordance with the Specification (Appendix H). The ditch width should be reduced at the location of a culvert so as to minimise the quantity of loose soil and consolidation required to bed the pipe.

### **6.0 MOLE DRAINAGE AND SUBSOILING**

#### **6.1 MOLE DRAINAGE**

##### **6.1.1 General**

Mole drainage should only be carried out over a suitable permanent under-drainage system with permeable backfill.

Sufficient soil sampling should be undertaken at the design stage to determine the suitability of the soil for mole drainage. The presence of a high clay content subsoil without pockets or lenses of sandy or gravely material would normally indicate that mole drains could be used. Some clay soils, however, do not form good lasting mole channels and advice from ADAS or other qualified persons may be necessary to determine the suitability of these soils for mole drainage. Local practice is a good guide.

##### **6.1.2 Timing of Operation**

The success of mole channel formation is, to a large extent, dependent upon soil moisture conditions at the time of moling and climatic conditions immediately following the operation. Adequate soil moisture must be present at moling depth to give a plastic consistency to the clay and to form a smooth, round, stable channel. Surface conditions must be suitable to provide traction and dry enough to allow fissuring of the soil above the mole channel.

##### **6.1.3 Mole Channel Depth**

The inverts of mole channels should not normally be less than 500mm below ground level. Regional variations in actual depth are widespread but deviations from the minimum should only be made where scientifically justified. In all cases the mole channels should be deep enough to intercept the permeable fill placed over lateral drains.

Maximum depth of mole channels must not exceed that required to maintain a clearance of at least 100mm between pipe and mole channel as shown in Appendix J.

##### **6.1.4 Spacing of Mole Channels**

Spacing should not normally exceed 4.5 x Depth to invert and in no circumstances should exceed 2.75m between adjacent mole channels.

#### 6.1.5 **Size and Shape of Mole Channels**

Mole Channels must be circular in shape and be a minimum of 75mm in diameter.

#### 6.1.6 **Direction of Moling Operations**

Mole Channels can be drawn both up and down hill but must always be drawn so as to intercept the permeable backfill over the underdrainage system.

#### 6.1.7 **Mole Drainage Equipment**

A Tracked or Wheeled Tractor of such weight and power sufficient to draw a mole channel evenly and continuously at the specified depth without loss of grip should be used. The mole plough must be designed and operated so that the "bullet" of the mole plough travels parallel to the general surface slope without being affected by minor surface irregularities or by pitching of the tractor. Adjustment for pitch of the mole plough leg must be possible and this should be set so as to give the correct alignment and circular shape of mole channels.

For work in stubble fields the mole plough beam should be fitted with a disc, coulter or raised beam to prevent trapped stubble causing the beam to ride-up and produce grade variations in the mole channel. A coulter is also required to prevent turf tearing on grassland.

#### 6.1.8 **Mole Channels Drawn Through Loose Soil**

Premature failure of mole channels may be experienced when they are drawn through loose or unconsolidated soil. Infilled ditches, piped ditches or unconsolidated trenchless heave can cause moles to collapse.

To improve the life of initial moling in the above circumstances the soil should be consolidated before moling.

### 6.2 **SUBSOILING**

#### 6.2.1 **General**

This Specification refers to subsoiling or deep loosening undertaken as an integral part of a drainage system. It does not apply to subsoiling undertaken to remove hard pans or compacted layers during cultivations or other activities on the land.

Subsoiling to improve drainage should only be carried out over a suitable permanent underdrainage system.

Adequate soil examination must be made at the design stage to assess the need for subsoiling and the benefits affordable.

#### 6.2.2 **Timing of Operation**

The surface and the subsoil must be dry enough to give good traction with minimum surface damage and adequate shattering and fissuring at depth.

Subsoiling should be carried out as late as possible in the cultivation plan of the field to avoid re-compaction of loosened soil. Timing must be decided in conjunction with the client but subsoiling must never be undertaken in wet conditions.

#### 6.2.3 **Subsoiling Depth**

Subsoiling depth must be sufficient to intercept any permeable fill placed over the drains. Subsoiling depth in these situations shall not normally be less than 450mm from the surface.

When subsoiling over mole channels the subsoiling depth must allow a minimum of 100mm clearance between the tine and the roof of the mole channel.

#### 6.2.4 **Tine Spacing**

Tine spacing is a function of depth, soil moisture condition, and the shape of the tine used. Tine spacing must be close enough to ensure the adequate disturbance and loosening of the soil between the successive passes of single tine machines or between adjacent tines on multi-tine machines. The maximum tine spacing permitted is 1.25m.

Frequent excavations should be made during subsoiling to ascertain the extent of soil shatter. The tines should be adjusted accordingly to give the required even distribution of loosened soil.

#### **6.2.5 Direction of Subsoiling**

Subsoiling should be carried out at approximately right angles to the underdrainage system.

#### **6.2.6 Subsoiling Equipment**

The tractor must be of sufficient power to draw the subsoiler at the required depth. Spacing on multi-tined subsoiling machines must be adjustable and set to give optimum soil disturbance.

In grassland, surface disturbance should be minimised using a suitably designed subsoiler.

### **7.0 MISCELLANEOUS ITEMS RELATING TO DITCHING AND UNDERDRAINAGE**

#### **7.1 Hill Gripping**

The channels of such surface drainage systems are to be formed in a tapered section, being nowhere less than 375mm deep, with a clean bed 150mm wide, and 450mm top width.

The excavated material should be placed on the downslope side of the grip not less than 500mm from the near edge. The bed of the grip is to be continuously graded towards one or both ends of its length. Each grip is to be connected to its outfall channel with sides and beds merging in a clean and undiminished cross-section. Channels shall run at an angle across main slopes at a gradient designed to minimise the risk of erosion.

#### **7.2 Structures to House Pumps and Associated Equipment**

Buildings to house pumps and associated equipment are to be properly designed and constructed for their purpose. Provision is to be made in buildings for adequate heating, ventilation and lighting. The dimensions and design should allow for easy access for inspection, servicing, repairs, installation, heating and removal of pumping plant, etc.

#### **7.3 Drain Jetting**

Where drain jetting is used to clean underdrains of silt accumulation or other deposits, operator and equipment shall be suitable for the work.

Water pressure and volume of flow must be sufficient to dislodge and remove the accumulated material without causing scouring or displacement of pipes or tiles.

#### **7.4 Spring Drainage**

Where springs are the major problem, test holes should be dug to identify the depth of the spring source and determine rate of flow. As flow rates are generally high, interceptor drains should not normally be less than 100mm diameter. Permeable backfill is required around the pipe to ensure a positive connection with the spring seepage.

### **8.0 CONSERVATION**

#### **8.1 General Considerations**

Careful consideration should be given to the landscape and its wildlife habitats when undertaking ditching and underdrainage works. Suitable planning beforehand can ensure that the execution of drainage operations and their future maintenance will have a minimal effect on the environment.

Furthermore, a new scheme can often provide an opportunity to create new conservation features such as ponds. Advice is available from ADAS and the Farming and Wildlife Advisory Group (FWAG).

- 8.2 **Water Courses**  
Special care should be taken when using herbicides for the maintenance of ditches and watercourses; they should be used very selectively and in accordance with the "Code of Practice" (obtainable from MAFF Divisional Offices) and manufacturers' instructions.
- 8.3 **Sites of Special Scientific Interest**  
Where drainage works are proposed on or adjacent to a Site of Special Scientific Interest, consultation with English Nature will be necessary. Before felling any trees the Forestry Commission and/or Local Authority should be contacted regarding felling licences and Tree Preservation Orders.
- 8.4 **Ancient Monuments**  
Where drainage operations are proposed on a scheduled "Ancient Monument", the consent of the Department of the Environment will be required.

## 9.0 **SAFETY**

- 9.1 **General**  
Due regard must be paid to all safety measures both on site and during transport. All Acts and Regulations concerning Road Traffic and Safe Working Practices must be adhered to.
- 9.2 **Health and Safety at Work Act (HASAWA) - General**  
Attention is drawn to the requirements of this Act. The General Duty provisions require that systems of work shall be adopted and plant and equipment used, that are, so far as reasonably practicable, safe and without risks to the health of persons at work and others who may be at risk from the activities of persons at work. Where five or more workers are employed employers are required to have a written safety policy.
- 9.3 **Important Safety Aspects of Field Drainage Works**  
Certain specific provisions of the HASAWA apply to the installation of field drainage schemes, including in some circumstances, regulations made under the Agricultural (Safety, Health and Welfare Provisions) Act 1956 and the Factories Act 1961. These provisions, which are now enforceable under the HASAWA have statutory application.  
Whether or not any of the regulations apply to a particular scheme the standard of protection prescribed in them should be adopted.  
Attention is drawn to the importance of ensuring that anything which may create a hazard and, in particular parts of machinery, are adequately guarded and that excavations are safe and adequately supported. Temporary excavations should be covered or guarded when the site is left, to reduce the risk of accidents to children and animals.

The following regulations contain requirements specific to the Land Drainage Industry.

Health & Safety at Work Act 1974 (HASAWA)  
The Reporting of Injuries, Diseases and Dangerous Occurrences Regulations 1985 (RIDDOR)  
The Manual Handling Operations Regulations 1992  
The Personal Protective Equipment at Work Regulations 1992  
The Control of Substances Hazardous to Health Regulations 1994 (COSHH)  
The Construction (Design and Management) Regulations 1994 (CDM)  
The Construction (Health Safety and Welfare) Regulations 1996

#### 9.4 **Underground Services**

The detailed procedures for avoiding danger from buried electricity cables is given in Guidance Note GS33 available from the Health and Safety Executive.

##### 9.4.1 **Notification**

All interested parties who have buried services in the land to be drained must be approached and enquiries made in writing as to the nature and location of such services.

Farmers must be questioned concerning the presence of any buried services before work commences.

##### 9.4.2 **Working in the Vicinity**

In all cases the buried utility should be located and exposed by hand digging before the drain laying. In the case of oil and gas pipelines an Inspector should be present during excavation and during pipe laying near or across the buried services.

All contact with buried services should be reported immediately to the responsible authority.

#### 9.5 **Overhead Electricity Cables**

The detailed procedure for working in the vicinity of overhead cables is laid down in Guidance Note GS6 available from the Health and Safety Executive. At all times the regulations should be strictly adhered to. If in doubt seek advice from local Electricity Board engineers.

- NOTE:**
- i) Safe working heights may be reduced in hot weather due to cable expansion or in wet weather when electricity may arc over larger distances than in dry weather.
  - ii) Never measure the height of overhead cables using a surveying staff. If the height is required a clinometer may be used.

#### 9.6 **Lasers**

Most common Laser transmitters used in land drainage work are classified as Class 3B. Very little safety hazard is experienced in 3 B Lasers when the laser beam is rotating. Grade 3B Lasers must not be viewed when the beam is stationary.

On no account should the beam be viewed through any optical instrument.

Where such systems are used a person knowledgeable on laser safety should be in attendance.

Warning signs should be displayed on drainage machines and notice boards indicating "Laser in Use" should be used when working close to public places.

Failure to take adequate precautions in respect of Class 3B Lasers can be a contravention of the Health and Safety at Work 1974 and can result in permanent eye damage.

# APPENDIX A

## DRAINAGE PLANS

### STANDARD SYMBOLS AND COLOURS

Plans for underdrainage and ditching should conform to the following symbols and colours. Deviations from standard must be clearly shown on the key or legend.

Where necessary, the plan must include the depth and spacing of Moling or Subsoiling ditch dimensions, fencing specifications, culvert sizes or other relevant information.

#### PLASTIC PIPES

DIAMETER MM	COLOUR
60 MMØ	RED
80 MMØ	PURPLE
100,110,125 MMØ	GREEN*
160,170 MMØ	BLUE*
200,225 MMØ	YELLOW*
OVER 225 MMØ	BLACK

\* INDICATE DIA METER

#### OPEN DITCH



#### PIPE DRAINS



#### PIPE DRAINS

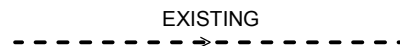

#### INSPECTION CHAMBERS

(IN OUTLET PIPE COLOUR)

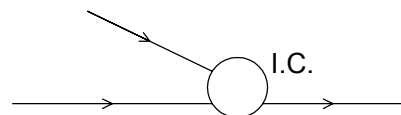

OR

#### INSPECTION CHAMBERS

(IN OUTLET PIPE COLOUR)

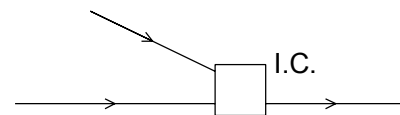

#### PIPE INLET CHAMBERS



#### CULVERTS

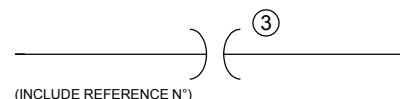

**PLAN SCALES:** UNDERDRAINAGE Not Less Than 1:2500  
DITCHING Not Less Than 1:10560

Plans should also include where relevant, the following information:

O.S. National Grid N°  
O.S. Edition  
Map Scale  
Parish Name  
Field Number

Certification of True Record  
Date  
Surveyors Name  
Scheme Reference  
North Point

NOTE: Ordinance Survey Maps are subject to Copyright. Details of copying charges can be obtained from local offices.

# APPENDIX B

## TYPICAL PIPE JOINTS AND CONNECTIONS

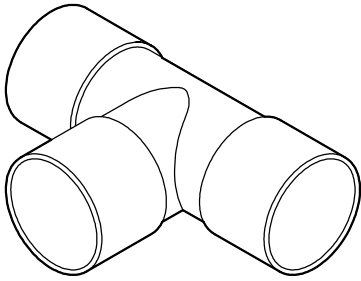

TEE PIECE

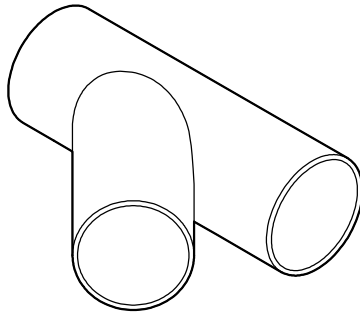

Y JUNCTION

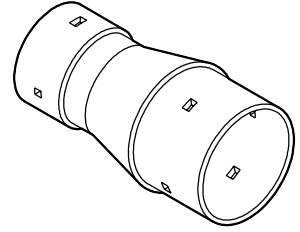

REDUCING COUPLING

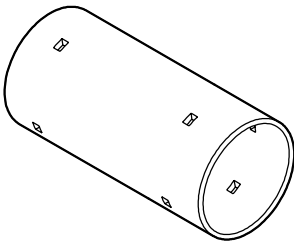

STRAIGHT COUPLING

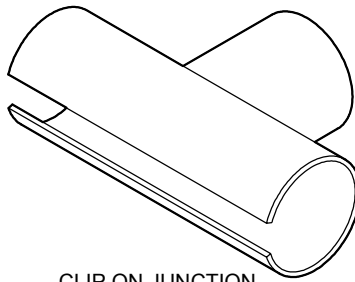

CLIP ON JUNCTION

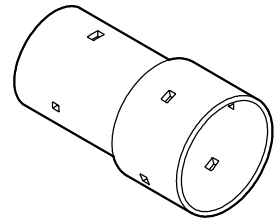

REDUCING COUPLING

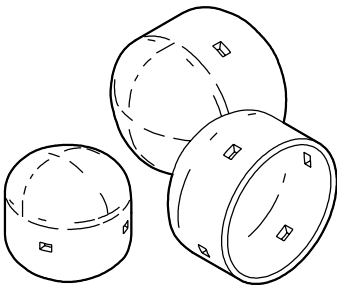

END CAPS

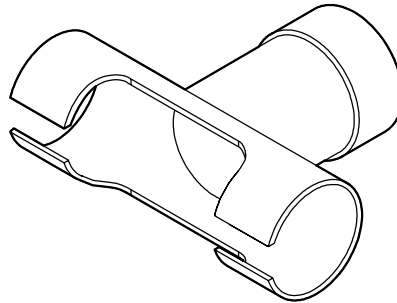

LATERAL JUNCTION (FIXED)

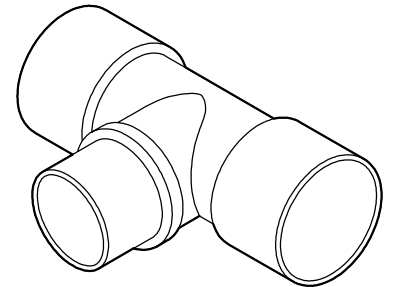

TEE REDUCING COUPLING

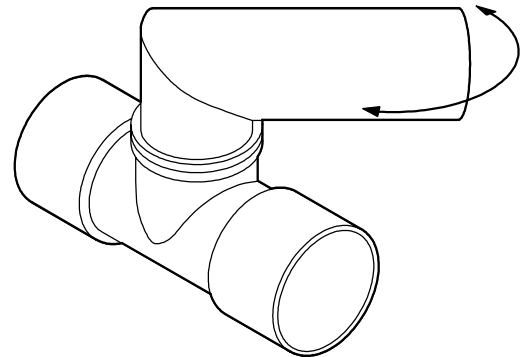

LATERAL JUNCTION (VARIABLE)

The joints and Connections shown here are schematic and represent acceptable types. Joints not shown may also be suitable and slight variations in design are acceptable.

Any joints must be well fitting and, if applicable, comply with BS requirements.

## APPENDIX C

### TYPICAL UNDERDRAINAGE HEADWALLS AND OUTFALLS

Outfalls may be constructed in a variety of materials. GRC Outfalls must have a rope, mesh or other method of anchoring the outfall in the ditch bank. Outfalls with precast holes or blank headwalls cut to suit pipe diameter are permissible.

#### GLASS REINFORCED CEMENT (GRC)

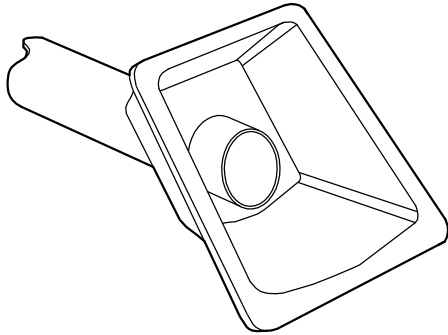

#### BRICK OR BLOCK BUILT

Durable, frost resistant concrete blocks. Bricks or natural stone may be used. Concrete foundations to be used where required.

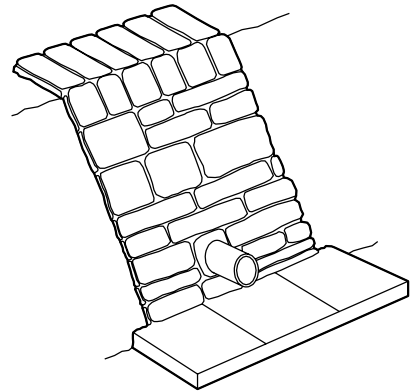

#### PRECAST CONCRETE

Precast headwalls must be suitably anchored

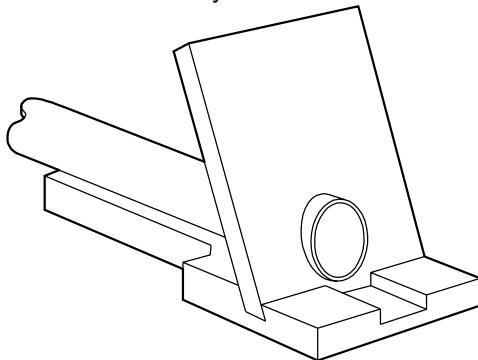

#### PRECAST CONCRETE HEADWALL

With wing walls

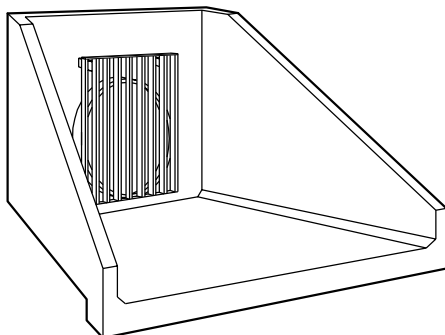

#### GENERAL NOTES:

- (i) All outfall pipes to be at least 1.5m long and frost resistant.
- (ii) Vermin gates to be fitted to all pipes.
- (iii) Other types of headwall meeting these standards are acceptable.

**NOTE:** The Outfall units illustrated are typical and are included as a guide only, the inclusion or omission of any proprietary item does not indicate the LDCA's approval or otherwise.

# APPENDIX D

## TYPICAL INSPECTION CHAMBERS

Inspection chambers are permitted in a variety of design and materials. Adequate strength must be ensured and attention is drawn to the NOTE on recommended dimensions. GRC units can only be used with very light loadings. The inclusion or omission of proprietary items does not indicate the LDCA's approval or otherwise, illustrations are for guide purposes only.

### GLASS REINFORCED CEMENT (GRC)

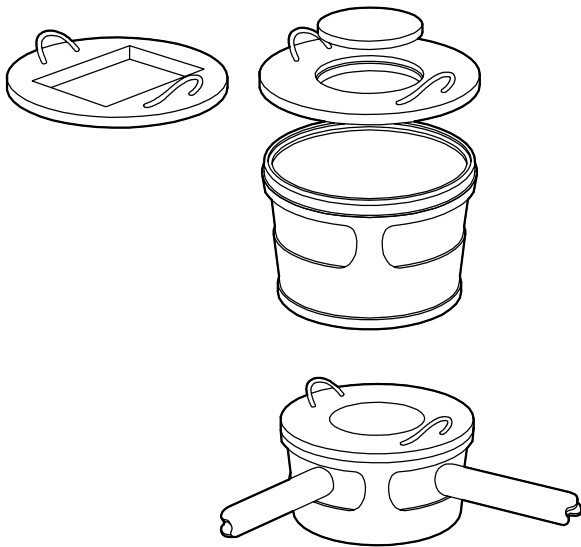

### PRECAST CONCRETE

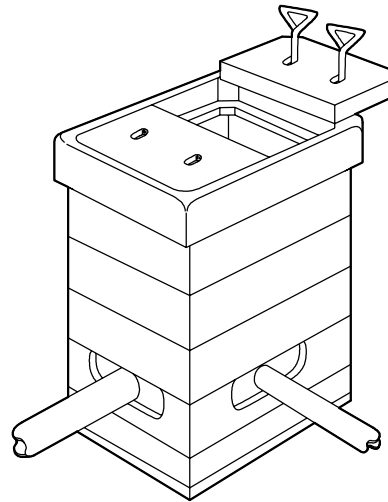

Minimum Cross Sectional Area of Chamber 0.25m<sup>2</sup> up to 1000mm deep  
Minimum Cross Sectional Area of Chamber 0.5m<sup>2</sup> up to 1800mm deep  
Minimum Cross Sectional Area of Chamber 1.0m<sup>2</sup> over 1800mm deep

**NOTES:** Inspection Chambers must be capable of withstanding loads applied from backfill and surface traffic.

The following minimum dimensions are recommended for built in situ chambers.

- Floor Slab / Base - 100mm (in Situ)
- Walls - 50mm (Surface)
- Covers - 50mm (Surface)
- 65mm (below Ground)

Covers must be capable of manhandling and be fitted with handles or lifting rings.

### BUILT IN SITU

(Square Construction)

Removable reinforced concrete slabs, preferably prestressed, provided with suitable lifting equipment.

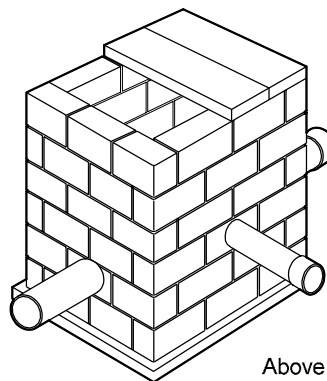

Above Ground Covers 50mm Thick  
Below Ground Covers 65mm Thick

**ALL PROPRIETARY ITEMS MUST EITHER CONFORM TO MAFF STANDARDS OR BE INDIVIDUALLY APPROVED FOR USE**

# APPENDIX E

## TYPICAL DRAIN INLETS AND SILT TRAPS

The following typical types of drain inlet may be used, the inclusion or omission of proprietary items does not indicate the IDCA's approval or otherwise.

### GLASS REINFORCED CEMENT (GRC)

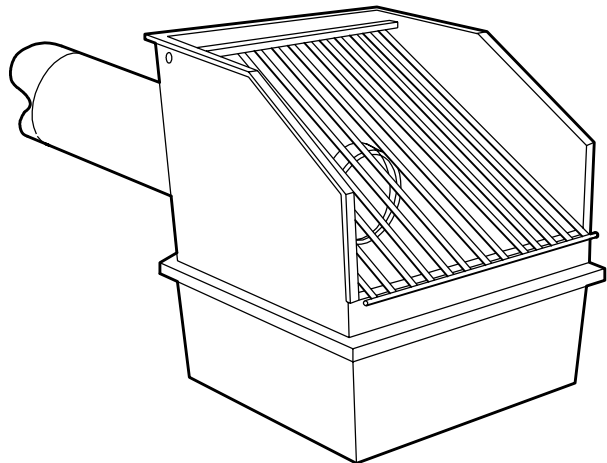
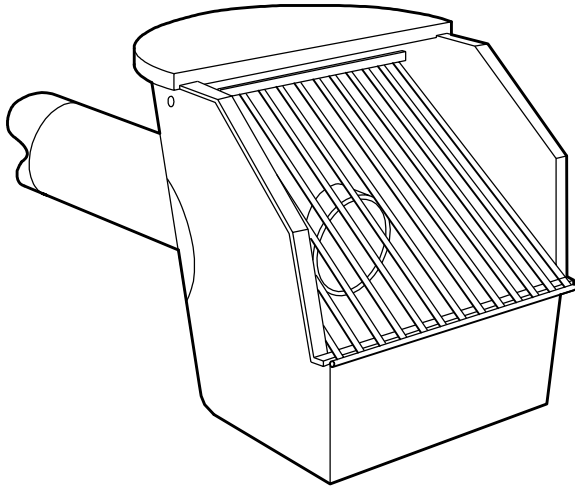

### PRECAST CONCRETE

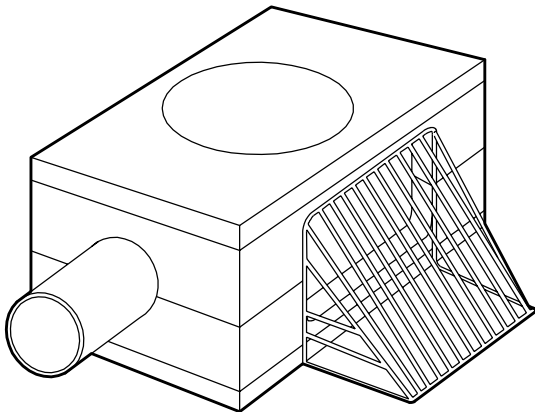

#### NOTES:

- (i) All Units must be securely located and strong enough for their purpose.
- (ii) Holes to accept Inlet Pipe must be carefully cut in GRC Units.
- (iii) Prefabricated Concrete Units must be selected to suit pipe size.
- (iv) All Blocks, Bricks or stone must be strong and frost resistant.
- (v) Minimum height of pipe above base must be 300mm.

**Published by The Land Drainage Contractors Association,  
NAC, Stoneleigh Park, Stoneleigh, Kenilworth, Warwickshire, CV8 2LG.**  
The Association reserves the right to change or modify this specification at any time without prior notice.