



# **GUIDELINES FOR DRAINAGE REINSTATEMENT (Pipelines)**

\*\*\*\*\*

## **Acknowledgements.**

The Land Drainage Contractors Association gratefully acknowledges the assistance of the many utility installation companies and their staff in producing these Guidelines. In particular, thanks are due to: British Institute of Agricultural Consultants, British Pipeline Agency Ltd., The National Farmers Union and the Water Authorities Association for their comments and suggestions.

The work and effort of the LDCA Technical Committee (R.E. Hughes, R. Longdin, and J.K. Hoare) is also warmly acknowledged.

January 1998.

Whilst all reasonable care has been taken to ensure the technical correctness of these Guidelines, the LDCA can accept no liability for errors, omissions, or the consequences of any such errors or omissions.

These Guidelines are not intended to form the basis of any specification or contract unless agreed separately in writing between the customer and the contractor. The Association reserves the right to change or modify any part of these Guidelines at any time without prior notice.

# **GUIDELINES FOR DRAINAGE REINSTATEMENT.**

## **CONTENTS.**

- 1.0. GENERAL
  - 1.1 Introduction
  - 1.2 Scope
  - 1.3 Definitions
  - 1.4 Statutory Authorities
  - 1.5 British Standards
  - 1.6 Materials not covered by British Standards
  - 1.7 Pipe Diameters
- 2.0 MATERIALS
- 3.0 PERMANENT REINSTATEMENT OF LAND DRAINS
  - 3.1 Permanent Header Drains
    - 3.1.1 Existing Land Drains
    - 3.1.2 Construction of Header Drains
    - 3.1.3 Header Drain Outfalls
  - 3.2. Permanent Cross-connection of Land Drains
    - 3.2.1 General
    - 3.2.2 Workmanship
- 4.0 TEMPORARY REINSTATEMENT OF LAND DRAINS
  - 4.1 General
  - 4.2 Workmanship and materials
- 5.0 MISCELLANEOUS ITEMS RELATING TO LAND DRAINAGE
  - 5.1 Marking and Recording Existing Land Drains
  - 5.2 Cleaning of Existing Drains
  - 5.3 Inspection, Measurement & Record Plans
  - 5.4 Location of Inspection Chambers
  - 5.5 Pre-construction Drainage Work
  - 5.6 Drainage outside the Working Width
  - 5.7 Topsoil Removal
  - 5.8 Method of Measurement
  - 5.9 Notifications
- 6. SUBSOILING
  - 6.1 General
- 7.0 MOLE DRAINING
  - 7.1 General
- 8.0 SAFETY
  - 8.1 General
  - 8.2 Regulations
  - 8.3 Underground Services
  - 8.4 Overhead Electricity Cables
  - 8.5 Lasers

# LDCA GUIDELINES FOR DRAINAGE REINSTATEMENT

## 1.0 GENERAL

### 1.1 Introduction

These Guidelines set out minimum standards for design, workmanship and materials used in land drainage of major pipelines and reinstatement of under-drainage disrupted by the course of such pipelines, as considered necessary by the Land Drainage Contractors Association Ltd (LDCA). Their use should result in a much higher standard of construction and subsequent performance of the reinstated land drainage.

Members of LDCA undertake to use and supply materials to the specified standards and to maintain standards of workmanship laid down in these Guidelines and in **LDCA's Technical Specification for Field Drainage Schemes (Jan. 1998)** (subsequently referred to as "**The Specification**") unless specifically contracted to do otherwise.

These Guidelines complement **The Specification** and should always be used in conjunction with the latest issue of that document.

It is strongly advisable that Drainage Installation be undertaken by a specialist land drainage contractor using suitable specialist machinery and trained staff.

### 1.2 Scope

These Guidelines deal with all aspects of land drainage on major pipeline installations: temporary and permanent drainage of the route, reinstatement of field drains and provision for outfalls etc. They do not fully cover landscaping or soil reinstatement except for subsoiling and moling which are regarded as drainage treatments.

The aim of these Guidelines is to ensure adequate drainage of the pipeline, easement and any other land affected by the pipeline during and after construction; and to restore the farm under-drainage to its previous standard.

### 1.3 Definitions

Terms used in these Guidelines are defined as follows:-

**Easement.** A legally binding agreement granted by a landowner to the promoter of a pipeline, either in perpetuity or for a long term, which sets out the rights and obligations of both parties (and their respective successors in title) in relation to the matter, but under which ownership of the land remains with the landowner.

**Working Width.** A strip of land usually wider than that covered by an easement, lease or wayleave, which is used by the contractor for the purposes of installing a pipeline.

**Pipeline.** Major Gas, Fuel, Water or Sewer pipe installation: Major Electricity or Communications Cable installation.

**Lateral Drain.** Existing subsurface agricultural drainage pipe - direct receiver of soil water over full length through slots in pipe walls or gaps at the joints.

**Collector Drain.** Existing restricted inlet main:- collects water from laterals, conveys the combined flow to an outfall (may also act as direct receiver of soil water).

**Interceptor Drain.** Existing subsurface drainage pipes:- located specifically to drain areas of seepage such as spring lines.

**French Drain.** New or existing drainage channel (trench), with or without drainage pipe, backfilled with suitable stone or gravel to the topsoil surface. Collects surface and sub-surface water flow. (Spurs of gravel-filled trenches may cross the pipeline obliquely to collect water at natural depressions of the route etc and to facilitate moling.)

**Outfall Drain.** Existing or new drainage pipe:- receives discharge from collector or interceptor drains, conveys it to an outfall.

**Header Drain.** New drain parallel with the pipeline on the upslope side of the working width:-

direct receiver of soil water, may act as a cut-off for ground and surface water flows. All existing land drains severed by the pipeline are intercepted by the header drain and their flow diverted to a suitable outfall.

**Easement Drain.** New drain parallel with the pipeline on the downhill side of the easement:- direct receiver of soil water, normally no direct connection of severed land drains. Collected water conveyed to suitable outfall.

**Cross Connection.** New drain reinstating an existing lateral, collector, interceptor or outfall drain severed by the pipeline:- reconnected over the pipeline.

**Outfall Crossing.** New outfall drain constructed over the pipeline.

**Access Drain.** New outfall drain constructed across a permanent access way used by heavy vehicles.

**Pre-Construction.** After contract commencement, but prior to topsoil removal.

**Post Construction.** After pipeline installation, but prior to topsoil replacement.

#### 1.4 **Statutory Authorities**

The requirements of statutory authorities having any interest in any part of the work shall be observed. The contractor shall comply with such Acts, Bye-Laws or Regulations which apply at the time of installation.

#### 1.5 **British Standards**

Where a British Standard is specified it is to be the current edition at the time of carrying out the work.

B.S. Publications can be purchased from BSI, Linford Wood, Milton Keynes, MK14 6LE.

#### 1.6 **Materials not covered by British Standards**

Where no British Standard exists from proprietary items, materials must be shown to be suitable for the specific purpose.

#### 1.7 **Pipe diameters**

The pipe diameters specified in the document above shall be the nominal diameter as identified by the manufacturer. This is normally the external diameter. Calculation of Pipe Sizes should be in accordance with MAFF Reference Book 345, "*The Design of Field Drainage Pipe Systems*".

### 2.0 **MATERIALS**

All materials used in reinstatement of agricultural land drainage should be in accordance with Section 3.1 of **The Specification**. Except that:

- \* Rigid plastic pipes whether of either single or twin wall construction should meet the following specification:- BS4660 or relevant BBA Agreement certificates.
- \* Permeable backfill materials shall meet the requirements of **The Specification (Clause 3.1.2.11.)**
- \* All sawn wood is to be pressure treated unless cut from heartwood of Oak, Sweet Chestnut or Yew.
- \* Flume pipes to drain the route (laid on the true clean bottom of ditches) must be of sufficient length and diameter to provide unrestricted flow of water across the working width at all times.

### 3.0 **PERMANENT REINSTATEMENT OF LAND DRAINS**

#### 3.1 **Permanent Header Drains**

##### 3.1.1 **Existing Land Drains**

Existing land drains severed by the pipeline trench, or damaged by the installation work (and not to be reinstated by cross-connection) shall be intercepted by a suitably sized Header Drain.

Generally Header Drains are preferred to cross-trench reconnections. Existing drainage pipes should be positively connected to the Header Drain in accordance with **The Specification (Section 3.2)**.

Existing drainage pipes superseded by a newer drain at a deeper level may be connected via an adequate width (100mm min.) and depth (50mm min.) of permeable backfill without a positive junction. Drainage pipes less than 100mm may also be connected via the permeable backfill. Old drains greater than 100mm diameter must be positively connected with purpose made junctions unless badly silted up.

Prior to connection of existing drainage pipes to the new Header Drain, all existing drains must be inspected and ensured clean for their entire length within the working width.

### 3.1.2. Construction of Header Drains

If possible, it is recommended that Header Drains are laid “Pre-Construction”, i.e. prior to topsoil stripping and before the pipeline is installed. Permeable backfill shall be placed over the pipes to within 300mm of original ground level. To minimise subsequent damage, the Header should be positioned as near to the edge of the working width as possible and excavated soil from the pipeline trench placed over it to prevent traffic damage.

Header Drains should be deep enough to intercept existing drains and to afford minimum cover needed to protect the pipe from damage. An optimum depth of 1200mm is recommended to intercept the bulk of groundwater flow and the majority of old drains. Adequate drainage must be provided to intercept water flow beneath the pipeline due to topography and soil type changes. The position of the Header Drain shall be parallel to, and upslope of, the main pipeline and installation shall be by the open trench method so as to expose any existing drainage pipes. Crossings of the pipeline should be kept to a minimum when designing the Header System. Header installation shall be undertaken using a specialist trenching machine fitted with suitable grade control. Pipes must be laid to an even grade on a firm bedding in accordance with the requirements contained in **The Specification (Section 3.2)**. “Post-Construction” drainage should, if possible, be installed before final topsoil replacement.

### 3.1.3 Header Drain Outfalls

The Header Drains will discharge to existing watercourses through precast concrete headwalls or to existing main drains.

Outfall construction must comply with **The Specification**. New outfall drain crossings of the pipeline shall be constructed in accordance with Section 4 of **The Specification**.

## 3.2 Permanent Cross-Connections of Land Drains

### 3.2.1 General

Where header drains are not used existing land drainage pipes must be reconnected across the pipeline.

The contractor shall notify the Engineer immediately should it become apparent that the pipeline will constitute a physical obstacle or barrier to the reinstatement, by cross-connection, of any particular land drain.

If possible the pipeline excavation should be deepened at these locations to ensure that a minimum clearance of 150mm is obtained between the crown of the pipe and any cross-connection of existing lateral or new outfall (header drain) crossing.

### 3.2.2. Workmanship

Following installation of the pipeline the surround shall be placed and the pipeline trench backfilled in compacted layers according to the Specification, up to a depth corresponding with the underside of the severed drains which are to be permanently reinstated by cross-connection. At the crossing points, only selected excavations material shall be used as backfill. In the absence of suitable backfill material (in agreement with the Engineer), lean mix concrete bagwork may be placed over the pipeline in layers to within 75mm of the cross connection-level. The length of the crossing shall be determined by inspection and shall be at least the distance between the undisturbed ground on either side of the pipeline plus at least 600mm either side for supports when crossing at right angles.

Where the cross-connected drain is a collector or outfall drain, the entire section of the drain on the vehicle running-track side of the easement shall also be replaced if necessary. The cross-connection shall be made ensuring that the line, level and gradient of the original drain (or new Header) is maintained.

A suitable length of hardwood timber (see Section 3.0), concrete beams or other support, (of cross section approximately 150mm x 75mm), shall be bedded centrally over the pipeline trench on the hand trimmed bed.

UPVC channelling shall be suitably fixed to the support and the crossing pipe laid and jointed in the channel in accordance with the Engineer’s requirements.

Permeable filling shall be carefully placed to surround and backfill the pipe to a depth of not more than 375 mm below the final topsoil surface level.

All work not specified in the cross-connection specification shall be in accordance with the latest edition of **The Specification**.

#### 4.0 TEMPORARY REINSTATEMENT OF LAND DRAINS

##### 4.1 General

Temporary reconnection of severed land drains is necessary to prevent water logging of fields and/or the pipeline route itself.

Temporary reconnection across the trench shall be made using watertight conduits of suitable size adequately supported.

All flowing drains shall be immediately cross-connected.

All other existing severed drains thought to be still active shall be temporarily cross connected as soon as possible.

Temporary reconnection must be maintained (except for short term removal to allow pipeline installation) until permanent reinstatement is completed.

##### 4.2 Workmanship and Materials

Materials used in temporary cross-connection shall be rigid, strong and shown to be suitable for their function.

Preparation of the trench backfill and temporary bed should be in accordance with these Guidelines and cross-connections made with rigid pipes using the methods described in Section 3.2.

All work not otherwise specified should be in accordance with **The Specification**.

#### 5.0 MISCELLANEOUS ITEMS RELATING TO DRAINAGE

##### 5.1 Marking and Recording Existing Land Drains

Land drains of any type or age must be marked and recorded as soon as they are exposed by the pipeline excavations or pre-construction drainage works.

Where an existing land drain is severed by the pipeline trench, it shall be clearly marked by two wooden pegs one in each of the right of-way-fences. A ribbon, coloured tape or string shall be tied to the fence above the pegs.

Where a drain runs at an acute angle with the pipeline trench, an additional peg shall be placed accurately in line with the drain where it intercepts the fence lines.

The pegs shall be 50mm x 50mm x 500mm long, pointed, placed firmly and have a colour code to distinguish between shallow drains (less than 450mm below the subsoil surface) which may be damaged by heavy plant, and deeper drains. The colour code shall be consistent throughout. A suggested colour scheme would be:

Blue marker - Land drain *less than* 450mm below subsoil level.

Blue & White marker - Land drain *more than* 450mm below subsoil level.

Alternatively a simpler system of blue marker posts may be employed to mark all existing land drains discovered.

A land drainage notebook should be maintained in which full details of drainage, depth of cover, size, type, chainage, direction and amount of flow, skew angle and condition (e.g. situation) of the existing drains are recorded as they are exposed.

If land drains are found during the removal of topsoil or when excavations are made after a pipeline trench excavation, they shall be duly marked and recorded and the Engineer's Representative notified.

Without limiting his liability for restoration of drainage the Contractor shall notify the Engineer's Representative of any land drain which is blocked or is otherwise patently defective when the drain is first exposed.

##### 5.2 Cleaning of Existing Drains

Where existing drains are to be connected to a Header Drain or cross-connected over the pipeline, checks must be made to ensure the drains are clean.

Drains should be free of soil, silt or other obstruction for the working width and for a reasonable distance beyond the working width as necessary.

Checking for blockages should be undertaken using drain rods and cleaning where necessary must be by an approved method.

Drains agreed between the contractor and the client to be too heavily silted or found to be defective may be replaced with a new drain as instructed.

### **5.3 Inspection, Measurement and Record Plans**

Prior to land drainage works, the Contractor should give adequate notice and inform the Engineer's Representative who shall make provision for the work to be inspected as it proceeds so as to avoid delaying the drainage and backfilling operations.

The inspection and measurement of drainage works shall be agreed with the Engineer's Representative before the works are backfilled.

In the case of "trenchless" installations the Contractor shall arrange for trial sections of trench to be opened at random to prove, to the satisfaction of the Engineer's Representative, that the drain is being properly installed with the specified depth of permeable filling. After such inspection the drain shall be reinstated by the Contractor. Where it is suspected that land drains have been missed and backfilled the Contractor shall make trial hole investigations as directed by the Engineer's Representative.

Land drainage record drawings shall be prepared on the basis of the guidelines laid down in **The Specification (Section 2.5, Appendix B)**. Additional nomenclature if required should be clearly defined in a suitable key.

### **5.4 Location of Inspection Chambers**

Inspection chambers may be required at:

- a) The junction of two or more main drains with an outfall drain
- b) Locations where an existing inspection chamber is demolished or made redundant by the pipeline works.
- c) An abrupt change of direction in an outfall drain
- d) Locations indicated by the Engineer's Representative.

Construction and Workmanship should conform to that laid down in **The Specification** unless otherwise determined.

### **5.5 Pre-Construction Drainage Works**

In certain locations the Contractor may be instructed to install permanent pre construction drainage works.

Elsewhere, and especially where grading, site terracing and benching, the Contractor, as part of his temporary work, shall provide temporary cut-off drains or grips as necessary to ensure that the Works are drained and kept free of ground and surface water which could adversely affect the condition of the site.

The installation of permanent or temporary pre-construction drains shall not relieve the Contractor of his obligations in respect of controlling and dealing with the flow of water from land drains subsequently severed by the pipeline trench, or surface run-off or ground seepage.

### **5.6 Drainage Outside the Working Width**

Where works need to be constructed beyond the easement fencing, the Employer through his appointed Land Agents, will negotiate the necessary rights of access and easements. The Contractor should consult all relevant Statutory Authorities and Public Utilities before commencing any excavations to satisfy himself as to the exact positions of existing services which may affect or be affected by the construction of the Works and to take all precautions and measures required.

### **5.7 Topsoil Removal**

Unless specifically required otherwise, topsoil need not be removed prior to drainage installation with specialist drainage machinery of the open trench or trenchless variety. Where backacters are used topsoil stripping may be required.

### **5.8 Method of Measurement**

All drain depths should be measured from the original topsoil level *not* the subsoil level.

## 5.9 Notifications

Design of the land drainage scheme should be completed before pipeline construction commences so that service enquiries and notifications can be made well in advance. Landowners or tenants should be notified before drainage work commences to allow inspection of the work if required.

## 6.0 SUBSOILING

### 6.1 General

These Guidelines refer to subsoiling or deep loosening undertaken as an integral part of a drainage system. They do not apply to subsoiling undertaken to remove hard pans or compacted layers during cultivations or other activities on the land.

Subsoiling to improve drainage should only be carried out over a suitable permanent under-drainage system and must conform to the standards laid down in **The Specification**.

## 7.0 MOLE DRAINAGE

### 7.1 General

Mole drainage should only be carried out over a suitable permanent under-drainage system with permeable backfill or gravel-filled spur drains over the pipeline and must conform to the standards laid down in **The Specification**.

Following pipeline installation, all the land upslope of the pipeline will require remoling and facility must be made, by way of suitable spurs, to cross the pipeline without collapse. The shorter the length of the moles crossing the trench line the less the risk of serious failure due to mole collapse. Moling across the trench line cannot be recommended unless header drains are intercepted by the mole channels as close as possible to the trench.

Moles drawn across a pipeline trench should not be expected to survive until natural settlement and consolidation has occurred. The time required for this will vary according to soil type and conditions during disturbance.

## 8.0 SAFETY

### 8.1 General

Due regard must be paid to all safety measures both on site and during transport. All Acts and Regulations concerning Road Traffic and Safe Working Practices must be adhered to. **The Specification** draws attention to the requirements of the Health and Safety at Work Act 1974, special safety aspects relating to land drainage and procedures for working in the vicinity of pipelines and buried services.

“Work in the vicinity of oil pipelines is controlled by statutory provisions under the Requisitioned Land and War Works Act 1948, the Land Powers (Defence) Act 1958 or the Pipelines Act 1962. Any work within 10ft (3m) of each side of an oil pipeline is a contravention and must have prior agreement of the pipeline owner.”

### 8.2 The following regulations contain requirements specific to the Land Drainage Industry.

8.2.1 Health & Safety at Work Act 1974 (HASAWA)

8.2.2 The reporting of Injuries, Diseases and Dangerous Occurrences Regulations 1985 (RIDDOR)

8.2.3 The Manual Handling Operations Regulations 1992

8.2.4 The Personal Protective Equipment at Work Regulations 1992

8.2.5 The Control of Substances Hazardous to Health Regulations 1994 (COSHH)

8.2.6 The Construction (Design and Management) Regulations 1994 (CDM)

8.2.7 The Construction (Health, Safety and Welfare) Regulations 1996

### 8.3 Underground Services

The detailed procedures for avoiding danger from buried electricity cables is given in Guidance Note GS33 available from the Health and Safety Executive.

### **8.3.1 Notification**

All interested parties who have buried services in the land to be drained must be approached and enquiries made in writing as to the nature and locations of such services. Farmers must be questioned concerning the presence of any buried services before work commences.

### **8.3.2 Working in the Vicinity**

In all cases the buried utility should be located and exposed by hand digging before the drain laying. In the case of oil and gas pipelines an Inspector should be present during excavation and during pipe laying near or across the buried services. All contact with buried services should be reported immediately to the responsible authority.

### **8.4 Overhead Electricity Cables**

The detailed procedure for working in the vicinity of overhead cables is laid down in Guidance Note GS6 available from the Health and Safety Executive. At all times the regulations should be strictly adhered to. If in doubt seek advice from local Electricity Board engineers.

#### **NOTE:**

- i) Safe working heights may be reduced in hot weather due to cable expansion or in wet weather when electricity may arc over larger distances than in dry weather.
- ii) Never measure the height of overhead cables using a surveying staff. If the height is required a clinometer may be used.

### **8.5 Lasers**

Most common Laser transmitters used in land drainage work are classified as Class 3B. Very little safety hazard is experienced in 3B Lasers when the laser beam is rotating.

Grade 3B Lasers must not be viewed when the beam is stationary.

Warning signs should be displayed on drainage machines, and notice boards indicating "Laser in Use" should be used when working close to public places.

**APPENDIX A**  
**DRAINAGE PLANS**  
**STANDARD SYMBOLS AND COLOURS**

Plans for underdrainage and ditching should conform to the following symbols and colours. Deviations from standard must be clearly shown on the key or legend. Where necessary, the plan must include the depth and spacing of Moling or Subsoiling ditch dimensions, fencing specifications, culvert sizes or other relevant information.

**PLASTIC PIPES**

DIAMETER MM	COLOUR
60 MMØ	RED
80 MMØ	PURPLE
100, 110, 125 MMØ	GREEN*
160, 170 MMØ	BLUE*
200, 225 MMØ	YELLOW*
OVER 225 MMØ	BLACK

\* INDICATE DIAMETER

**OPEN DITCH**



**PIPE DRAINS**



**PIPE DRAINS**



**INSPECTION CHAMBERS**  
(IN OUTLET PIPE COLOUR)

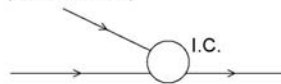

OR

**INSPECTION CHAMBERS**  
(IN OUTLET PIPE COLOUR)

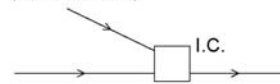

**PIPE INLET CHAMBERS**



**CULVERTS**



**PLAN SCALES:** UNDERDRAINAGE Not Less Than 1:2500  
DITCHING Not Less Than 1:10560

Plans should also include where relevant, the following information:

O.S. National Grid N°  
O.S. Edition  
Map Scale  
Parish Name  
Field Number

Certification of True Record  
Date  
Surveyors Name  
Scheme Reference  
North Point

NOTE: Ordinance Survey Maps are subject to Copyright. Details of copying charges can be obtained from local offices.

**APPENDIX B**  
**TYPICAL PIPE JUNCTIONS AND CONNECTIONS**

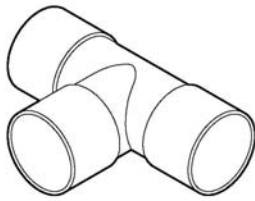

TEE PIECE

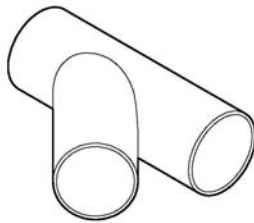

Y JUNCTION

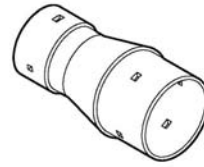

REDUCING COUPLING

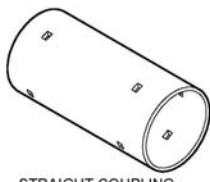

STRAIGHT COUPLING



CLIP ON JUNCTION

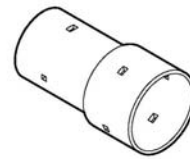

REDUCING COUPLING

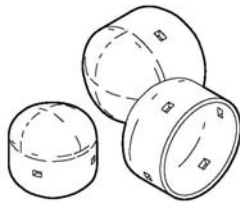

END CAPS

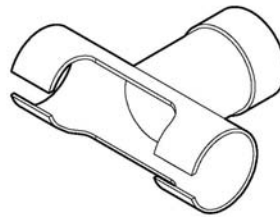

LATERAL JUNCTION (FIXED)

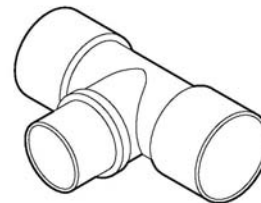

TEE REDUCING COUPLING

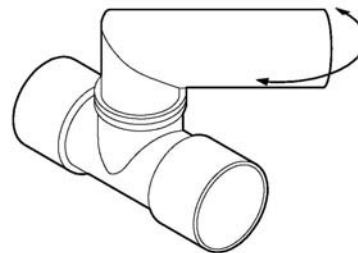

LATERAL JUNCTION (VARIABLE)

The junctions and Connections shown here are schematic and represent acceptable types. Junctions not shown may also be suitable and slight variations in design are acceptable.  
 Any junctions must be well fitting and, if applicable, comply with BS requirements.

## APPENDIX C

### TYPICAL UNDERDRAINAGE HEADWALLS AND OUTFALLS

Outfalls may be constructed in a variety of materials. GRC Outfalls must have a rope, mesh or other method of anchoring the outfall in the ditch bank. Outfalls with precast holes or blank headwalls cut to suit pipe diameter are permissible.

#### GLASS REINFORCED CEMENT (GRC)

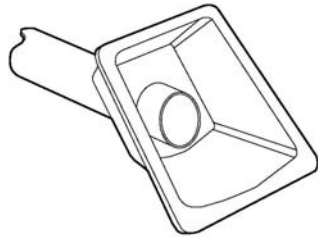

#### BRICK OR BLOCK BUILT

Durable, frost resistant concrete blocks. Bricks or natural stone may be used. Concrete foundations to be used where required.

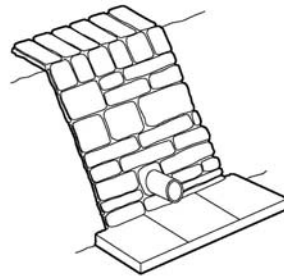

#### PRECAST CONCRETE

Precast headwalls must be suitably anchored

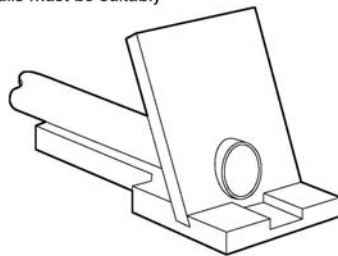

#### PRECAST CONCRETE HEADWALL

With wing walls

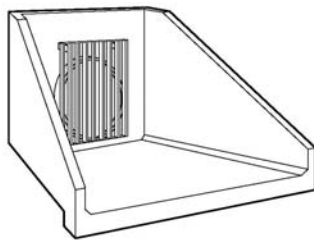

#### GENERAL NOTES:

- (i) All outfall pipes to be at least 1.5m long and frost resistant.
- (ii) Vermin gates to be fitted to all pipes.
- (iii) Other types of headwall meeting these standards are acceptable.

**NOTE:** The Outfall units illustrated are typical and are included as a guide only, the inclusion or omission of any proprietary item does not indicate the LDCA's approval or otherwise.

## APPENDIX D

### TYPICAL INSPECTION CHAMBERS

Inspection chambers are permitted in a variety of design and materials. Adequate strength must be ensured and attention is drawn to the NOTE on recommended dimensions. GRC units can only be used with very light loadings. The inclusion or omission of proprietary items does not indicate the LDCA's approval or otherwise, illustrations are for guide purposes only.

#### GLASS REINFORCED CEMENT (GRC)

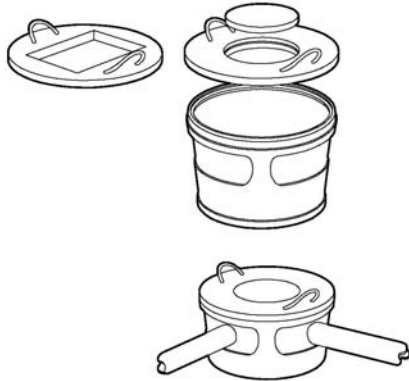

#### PRECAST CONCRETE

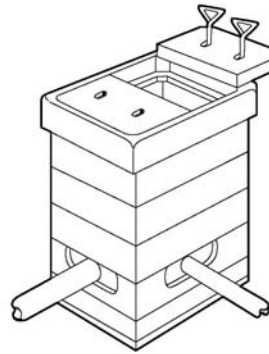

Minimum Cross Sectional Area of Chamber 0.25m<sup>2</sup> up to 1000mm deep  
Minimum Cross Sectional Area of Chamber 0.5m<sup>2</sup> up to 1800mm deep  
Minimum Cross Sectional Area of Chamber 1.0m<sup>2</sup> over 1800mm deep

**NOTES:** Inspection Chambers must be capable of withstanding loads applied from backfill and surface traffic.

The following minimum dimensions are recommended for built in situ chambers.

Floor Slab / Base - 100mm (in Situ)  
Walls - 50mm (Surface)  
Covers - 50mm (Surface)  
-65mm (below Ground)

Covers must be capable of manhandling and be fitted with handles or lifting rings.

#### BUILT IN SITU (Square Construction)

Removable reinforced concrete slabs, preferably prestressed, provided with suitable lifting equipment.

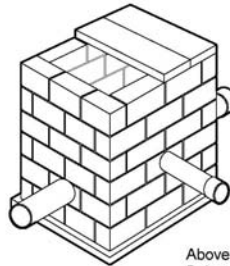

Above Ground Covers 50mm Thick  
Below Ground Covers 65mm Thick

**ALL PROPRIETARY ITEMS MUST EITHER CONFORM TO MAFF STANDARDS OR BE INDIVIDUALLY APPROVED FOR USE**

## APPENDIX E

### TYPICAL DRAIN INLETS AND SILT TRAPS

The following typical types of drain inlet may be used, the inclusion or omission of proprietary items does not indicate the IDCA's approval or otherwise.

#### GLASS REINFORCED CEMENT (GRC)

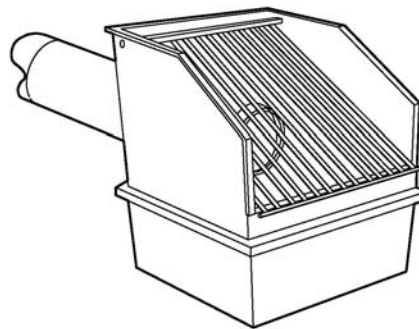
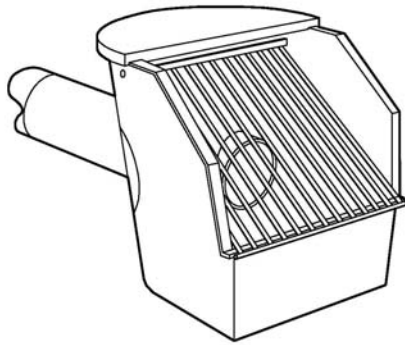

#### PRECAST CONCRETE

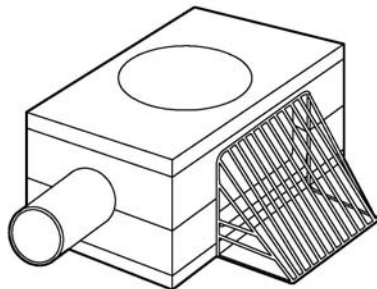

#### NOTES:

- (i) All Units must be securely located and strong enough for their purpose.
- (ii) Holes to accept Inlet Pipe must be carefully cut in GRC Units.
- (iii) Prefabricated Concrete Units must be selected to suit pipe size.
- (iv) All Blocks, Bricks or stone must be strong and frost resistant.
- (v) Minimum height of pipe above base must be 300mm.

**Published by The Land Drainage Contractors Association,  
NAC, Stoneleigh Park, Stoneleigh, Kenilworth, Warwickshire, CV8 2LG.**  
The Association reserves the right to change or modify this specification at any time without prior notice.